



ATLANTIS-PAK

Leader In Innovative
Packaging Solutions

HEAT-SHRINK BAGS



AMIVAC MBL

Process Operating Manual



1. APPLICATION

The **AMIVAC MBL** heat-shrink bags are barrier bags designed for vacuum packaging, storage and sale of sausage products; delicatessen products; cheeses without ripening; soft and brine-ripened cheeses; and sliced cheeses.

These bags are **not** intended for packaging of the following products:

- products on bones;
- products in decorative coating, with coarse inclusions;
- dry-salted products with salt crystals remaining on the surface;
- products with rough or sharp edges.

The **AMIVAC MBL** bags are made from multilayer tubular film consisting of polyamide, polyethylene and a modified polyolefin covered by appropriate certificates of conformity.

The production, use, storage and transportation of the bags are not harmful for the environment or human health.

2. PROPERTIES AND ADVANTAGES OF THE PRODUCTS

2.1. High barrier characteristics in relation to oxygen provide for a prolonged storage of the packaged products.

2.2. Low permeability to water vapor excludes moisture (weight) losses of the product during storage.

2.3. Demonstration of the product in all its attractiveness to the buyer due to the optical properties of the bag (transparency, gloss).

2.4. Possibility of sealing through the folds and overlaps, which raises productivity and reduces the need for re-packaging.

2.5. Individual protective packaging of the **AMIVAC MBL** bag packs guarantees protection from adverse external factors throughout the guaranteed storage term, and provides for an excellent sanitary and hygienic condition of the bags.

2.6. Absence of chlorine-containing substances. An increasing number of countries turn their attention to protection of the environment and utilization of packaging materials. Utilization of packaging free of chlorine containing substances is less harmful to the environment.





2.7. The **AMIVAC MBL** bags are made using only the materials and raw stuffs approved for direct contact with food products under the applicable laws of Russia, Ukraine, the Customs Union (Russia, Belorussia, Kazakhstan), the European Union, and the USA. This means that in case of export deliveries and the requirement for local certification, it will not be a problem to obtain the permitting hygienic documents for the **AMIVAC MBL** bags.

3. ASSORTMENT OF THE PRODUCTS

The assortment of the **AMIVAC MBL** is shown in Table 1

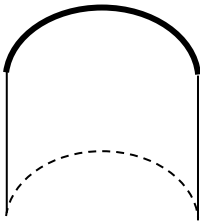
Table 1

	Seals		
	Straight	Semicircular	Lateral seals
Bag width	from 80 to 450 mm	from 80 to 450 mm	from 80 to 300 mm
Bag length	from 100* to 1200 mm	from 100* to 1200 mm	from 140 to 450 mm
Appearance			
Pasting on tape	Option	Option	Option

*From 300 mm when paste on a tape

Color of the bags: clear

Printing: The **AMIVAC MBL** bags can be used for a single- or double-sided printing. The number of the print colors is from 1+0 to 10+10. CMYK printing is optional.

The bags are supplied in the following forms:

- rolls with tear-off perforation;
- rolls without perforation;
- pasted on two bands (for automatic equipment)
- cut into separate bags inside transportation packs, each containing 100 bags.

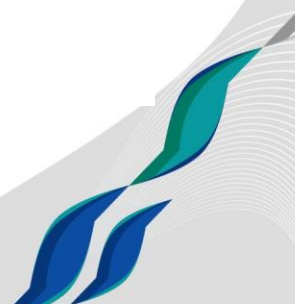

4. UTILIZATION TECHNOLOGY FOR THE AMIVAC MBL BAGS

4.1. Storage and transportation of the bags

4.1.1. The bags must be stored in dry and clean rooms, with the temperature not exceeding 35 °C, and the relative humidity not more than 80 %.

4.1.2. During the storage and transportation the cases with bags should not be exposed to high temperatures (more than 35 °C) or direct sunlight.

4.1.3. Never drop the boxes with casings or subject them to impacts.

4.1.4. If the bags were stored at a temperature below 0 °C, keep them at room temperature for at least 24 hours before opening the manufacturer's packing.

4.1.5. The remaining bags should be re-packed again into a new package under vacuum.

4.2. Selection of the required bag size

To determine the required width (S) of the bag, measure the perimeter of the product to be packaged in its widest part. Calculate the bag width by the formula:

Width = Perimeter of the product (in its widest part) x 0.55 (mm)

To determine the required length (L) of the bag, measure the perimeter of the product to be packaged in its longest part. Calculate the bag length by the formula:

Length = Perimeter of the product (in its longest part) / 2 +80 (100) mm

If the bag will be closed by clipping, add **100** mm to the calculated bag length value.

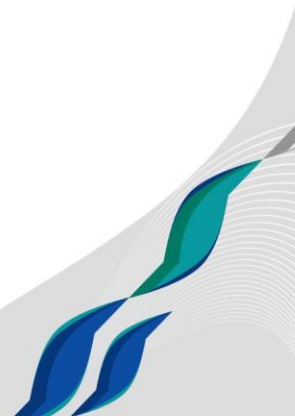

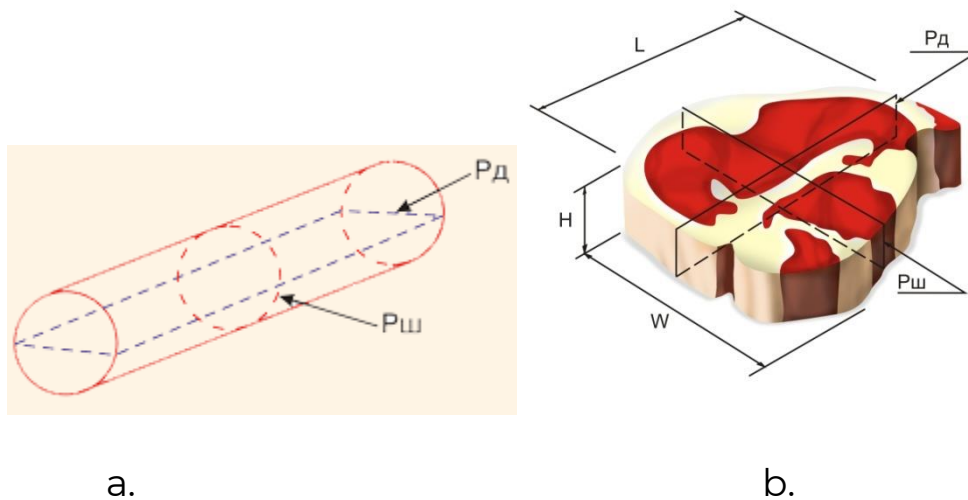

Fig.1

where $P_{ш}$ is the perimeter of the product in its widest part;
 $P_{д}$ is the perimeter of the product in its longest part.

4.3. Preparation of the bags for use

It is recommended to open the packs containing the bags immediately before use. If any bags taken out of the transportation packing remain unused, it is recommended to re-pack them under vacuum in a new package.

No contact of the bags with water is allowable before completion of the product packaging.

4.4. Packaging

Packaging of food products must be performed in a production / packaging room compliant with the requirements of the sanitary regulations and rules applicable to the food industry.

Packaging of the product will be performed by means of special equipment (vacuum packaging machines, clippers). Observe the operating modes recommended by the manufacturer of the packaging equipment to ensure a stable packaging process.

Comply with the following instructions.

4.4.1. Packaging on chamber-type machines:

- Check the sealing zone. Keep the sealing zone clean. No foreign admixtures are allowable, and the protective coating of the heating element must be free of burnt-through areas.

- Put the bag containing the product in the vacuum zone. The product inside the bag should be as close to the heat-sealing bar as possible (Fig.2), to improve the appearance and ensure the tight envelopment of the product.

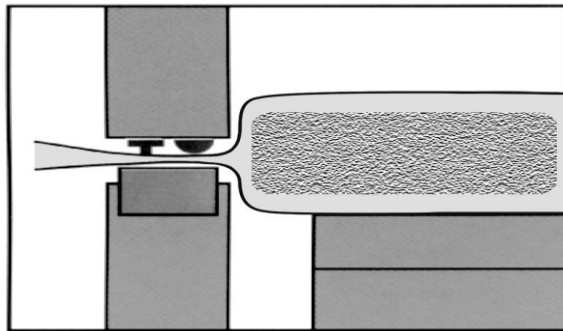

Fig.2

- Select the vacuum depth. The vacuum depth is adjusted depending on product to be packaged. Vacuum depth is 95 - 98% (residual pressure about 4.9 kPa). When packaging the products with high moisture content, the vacuum depth must be reduced (the higher is the moisture content, the less is the vacuum depth value).

-Select the mean sealing time. Increase or decrease the sealing time to achieve the optimal seam formation mode, as the bags are consumed (required adjustment depends on the condition of the equipment; if adjustment is necessary, it will take a period of 5-10 minutes, and 1-3 bags).

-If the bags are sealed with separate control of the strings, select such a time for string contact as to provide for free separation of the cutoff part of the bag.

-Evacuate the bag and heat-seal by closing the lid of the vacuum packaging equipment.

-After heat-sealing, the seam must be continuous and must show the imprint of the sealing bar of the packaging machine.

If the package sealing is lost, the product must be returned for re-packaging. Bags may not be re-used.

4.4.2. Packaging on chamberless machines (by clipping):

- Place the bag containing the product on the special tray of the machine, and put the open part of the bag on the nozzle (Fig. 3).

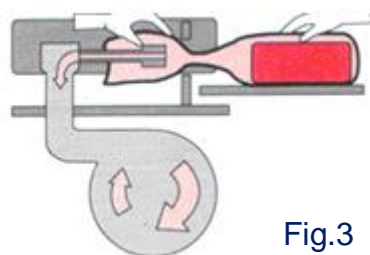

Fig.3

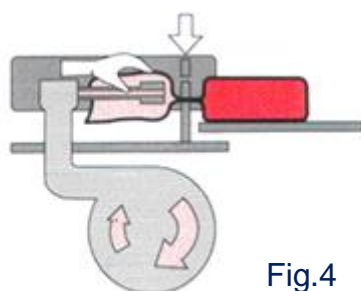

Fig.4

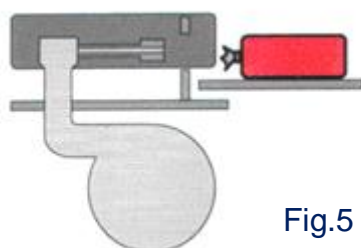

Fig.5

- Evacuation time is from 10 to 30 seconds, depending on the required vacuum depth. The maximum value is 0.05 bar.

- Pressure on the clip must be not less than 5 bar, but not more than 7.5 bar. Increase or reduce the pressure by means of the reduction valve (located at the pump) to achieve the optimal pressure. The clip must not puncture or cut the bag.

- If the clipper is provided with adjustment of the clip pressure value, select a pressure, at which the optimal fastening of the clip on the bag is achieved.

If advice is needed regarding adjustment of the equipment or use of consumables, consult the manufacturers of the equipment or any of their representatives.

See Table 5 for recommendations on selection of the clips when using vacuum clippers on the **AMIVAC MBL** bags.

Recommended clip types

Table 5

Bag width	Cryovac	Technoclip
100 – 200 mm	FL	H 548 T (DST)
205 – 300 mm	FH	H 550 T (DST)
305 mm or more	FC	H 550 T (DST)

Note: Package soft and brine-ripened cheeses in accordance with the Process Instruction on the use of **AMIVAC MBL** bags for production of soft and brine-ripened cheeses.

4.5. Heat shrinkage

Heat shrinkage of the bag containing the product is achieved in a heat-shrinking tank or tunnel. The equipment must provide for adjustment and control of the conditions and parameters of the technological process of heat shrinkage.

Heat shrinkage will be performed by immersion of the bag with the product in hot water or by sprinkling with hot water (steam) at a temperature from 90 °C to 95 °C during 2-3 seconds.

It is recommended to carry out the scheduled maintenance washing and treatment of the equipment.

4.6. Storage and transportation of products packaged in AMIVAC MBL bags

It is recommended to put the packaged products in a cold store with a temperature not higher than 6°C, not later than 20 minutes after packaging.

Note: Ripen and store soft and brine-ripened cheeses in accordance with the Process Instruction on the use of Amivac bags for production of soft and brine-ripened cheeses.

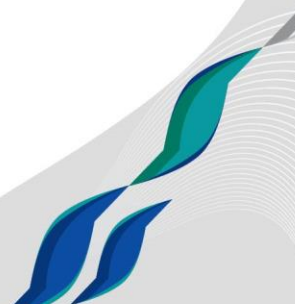

5. MANUFACTURER'S GUARANTEES

5.1. The Manufacturer guarantees conformity of the **AMIVAC MBL** bags with the Specification requirements subject to compliance with the required conditions of transportation and storage at the user's warehouse, and preservation of the integrity of the original packing.

5.2. The shelf life of bags is 1 year from the date of manufacture.





PCF ATLANTIS-PAK LLC
Address: 72 Onuchkina str., village of Lenin,
Aksay district, Rostov region,
346703 Russian Federation
Phones: +7 863 255-85-85 / +7 863 261-85-80
Fax: +7 863 261-85-79
www.atlantis-pak.top
info@atlantis-pak.top



Download on the
App Store



GET IT ON
Google Play

